

KEY FEATURES

- *Universal Input 85 to 305 Vac
- *Compact Size
- *High Reliability
- *Isolation Voltage 3000 Vac
- *Single line package

ELECTRICAL SPECIFICATIONS

INPUT

- *Input range----- 85-305 Vac (100-430Vdc)
- *Frequency----- 47-63 Hz
- *Input current----- 0.2A max (Full load @115Vac)
- *Inrush current----- 13A max (Cold start@115Vac,25°C)
- *Efficiency----- (Refer next page)

OUTPUT

- *Rating power----- (Refer next page)
- *Voltage accuracy--- +/-3% max.
- *Line regulation---- +/-1.5%
- *Load regulation---- +/-3% (10-100% load)
- *Over load protection
- *Short circuit protection

EMC

- *Conduction ----- EN55032
- *Radiation----- EN55032

PHYSICAL

- *Dimensions----- 26.4 x 14.73 x 11.0 mm

APPLICATIONS

- *Telecommunications
- *Test & industrial equipments

ENVIRONMENTAL

- *Operating temperature:
-40 to +85°C ambient
- *Humidity:
Operating; non-condensing, 20% to 95%
- *Storage temperature:
-40 to +105°C
- * Dielectric Strength(Hi-pot)
Input to Output: 3600Vac/5mA max / 1 minute

DERATING

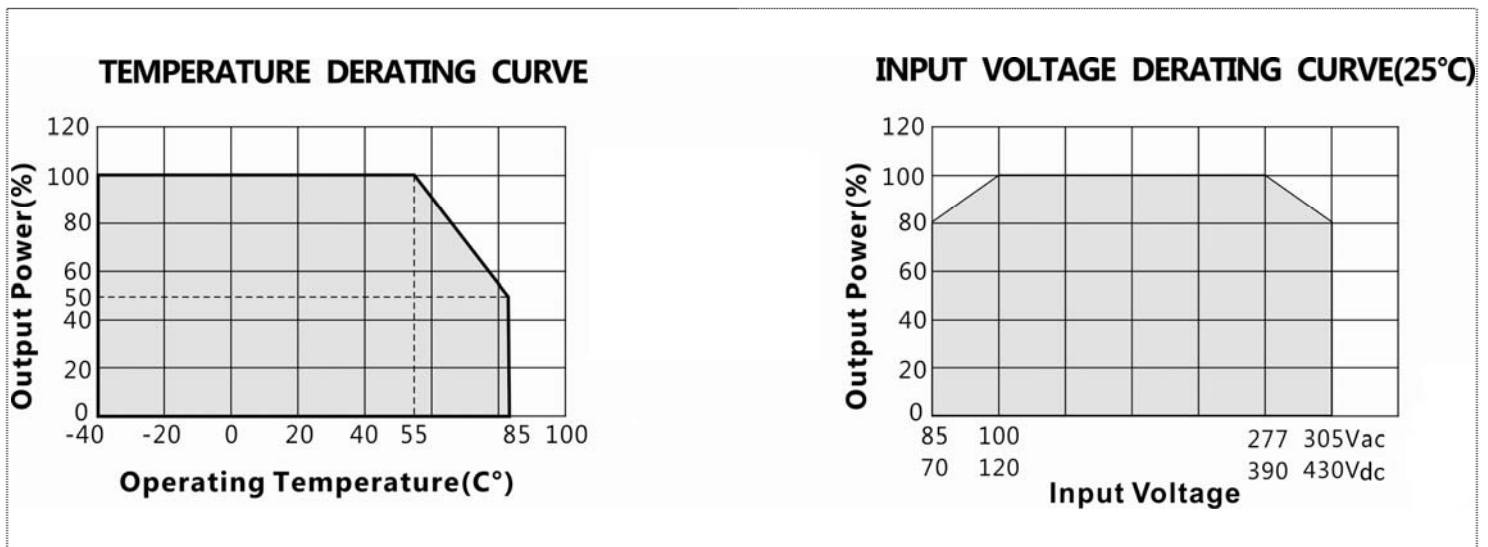

MODEL	OUTPUT VOLTAGE	OUTPUT CURRENT		OUTPUT POWER (W)	RIPPLE & NOISE	EFFICIENCY (Typ.)	CAPACITOR LOAD (Max.)
		Min.(A)	Max.(A)				
PSO03-0	3.3V	0.06	0.6	1.98W	150mV	67%	820uF
PSO03-1	5V	0.06	0.6	3W	150mV	72%	680uF
PSO03-2	9V	0.033	0.33	3W	150mV	76%	470uF
PSO03-3	12V	0.025	0.25	3W	150mV	77%	470uF
PSO03-4	15V	0.02	0.2	3W	150mV	78%	330uF
PSO03-6	24V	0.013	0.125	3W	150mV	80%	200uF

MODEL SELECTION CHART

MECHANICAL DIMENSIONS

PIN CONNECTIONS	
PIN	Function
1	AC(L)
2	AC(N)
3	+V(cap)
4	-V(cap)
5	-Vo
6	+Vo

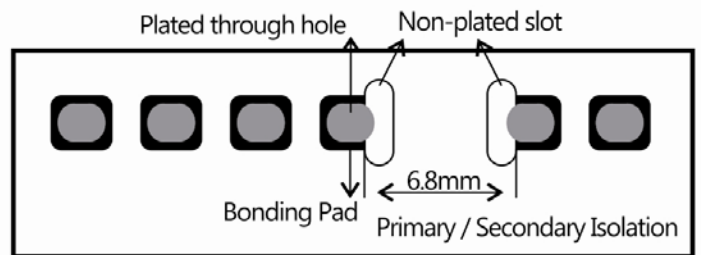
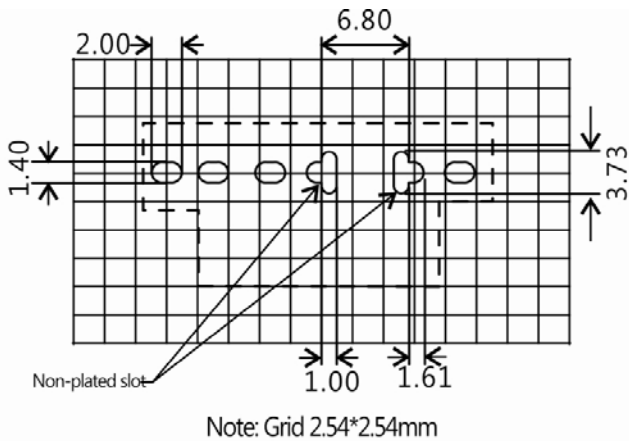
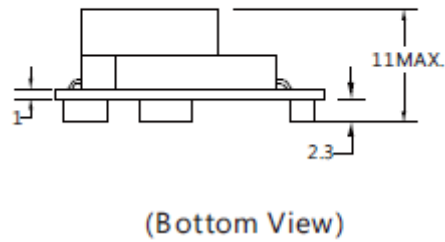
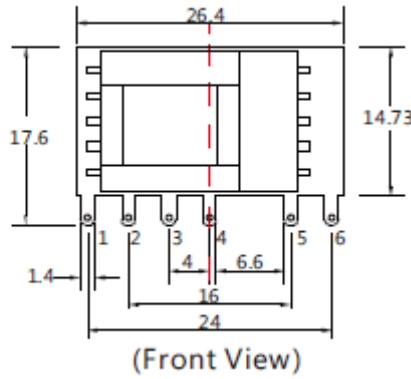

Note: There are two, non-metallic / non-plated, slots located between pins 4 and 5 that are required to maintain proper creepage distance and isolation between primary and secondary circuits

APPLICATION DESIGN REFERENCE

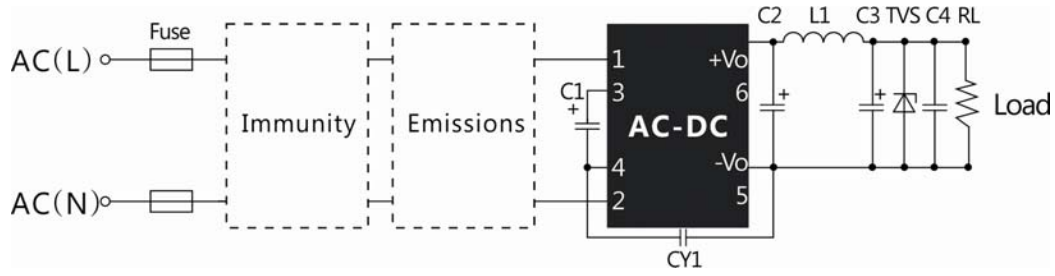

PSO03 Series additional component selection guide(no EMC devices)							
Part no.	C1 ¹ (required)	C2 (required)	L1 (required)	C3 ² (required)	C4	CY1 (required)	TVS ³
PSO03-0	22uF/450V (-40°C to 85°C with 85-305 Vac input)	470uF/6.3V (solid-state capacitor)	4.7 uF Max,60mΩ/ 2.2A	150uF/ 35V	0.1uF/ 50V (ceramic capacitor)	1.0nF/ 400Vac	SMBJ7.0A
PSO03-1		270uF/16V					SMBJ7.0A
PSO03-2	10uF/450V (-25°C to 85°C with 85-305Vac input) or (-40°C to 85°C with 165-305 Vac input)	(solid-state capacitor)		47uF/ 35V			SMBJ12A
PSO03-3							SMBJ20A
PSO03-4		220uF/35V		SMBJ20A			
PSO03-6				SMBJ30A			

Note:

1. Recommended to use a capacitor with ripple current > 200 mA at 100 KHz.
2. Recommended to use a high frequency, low ESR, electrolytic capacitor (<= 1.1Ω at -40°C) with at least 20% margin on voltage rating
3. A suppressor diode (TVS) is recommended to protect the downstream application in case of converter failure and should be rated for a minimum of 1.2 times the converter's output voltage.

PSO03 Series Enviromental and EMC selection guide						
Recommended circuit	Application environmental	Typical industry	Input voltage range	Enviroment temperature	Emissions	Immunity
1.	Basic application	None	85~305Vac	-40°C to 85°C	Class A	Class III
2	Indoor civil environment	Smart home/Home appliances(2 Y-caps)		-25°C to 55°C	Class B	Class III
	Indoor general environment	Intelligent building/ Intelligent agriculture		-25°C to 55°C	Class B	Class IV
3	Indoor industrial environment	Manufacturing workshope		-40°C to 85°C	Class A	Class IV
4	Outdoor general environment	ITS/Video monitoring/ Charging point/ Communication/Security and protection				

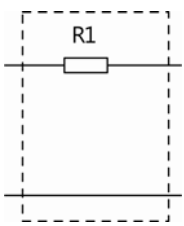
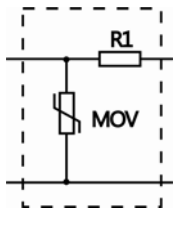
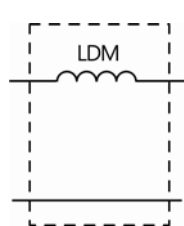
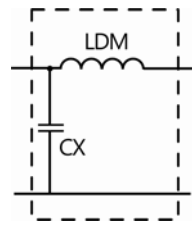
Immunity design circuits reference		Emissions design circuits reference	
Class III	Class IV	Class A	Class B
			

Circuit 1

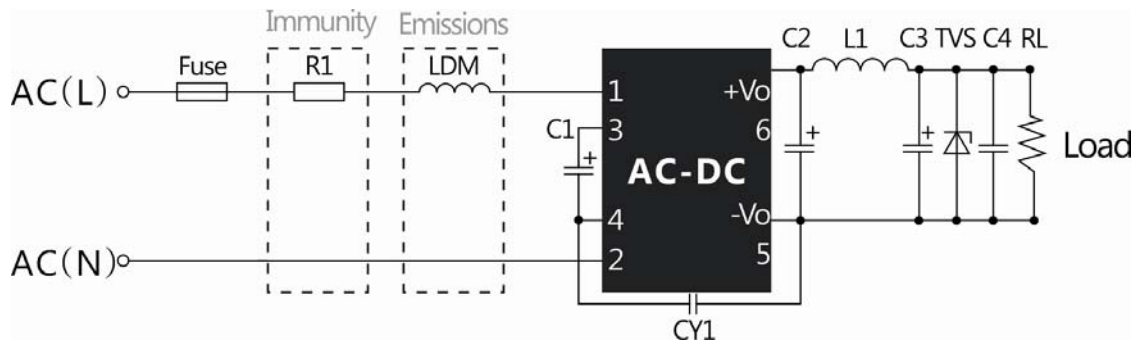

Table 1

Application environmental	Ambient temperature range	Imunity Class	Emissions Class
Basic application	-40°C~85°C	Class III	Class A

Component	Recommended value
FUSE(required)	1A/300V,slow blow
R1(wire-wound resistor, required)	12Ω/3W
LDM	1.2mH/4Ω max/0.2A min

Note: R1 must be a wire-wound resistor; do not use a chip or carbon film resistor.

Circuit 2

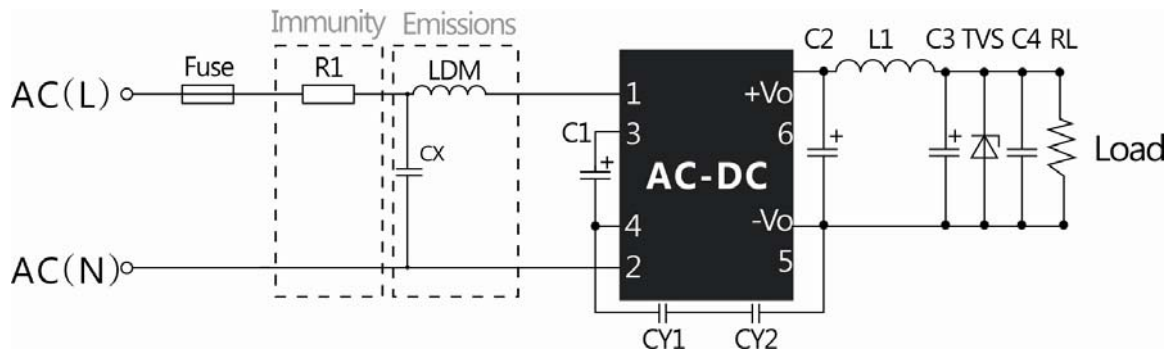

Table 2

Application enviromental	Ambient temperature range	Imunity Class	Emissions Class
Indoor civil / general	-25°C~55°C	Class III	Class B

Component	Recommended value
R1(wire-wound resistor, required)	12Ω/3W
LDM	1.2mH/ 4Ω/0.2A
CX	0.1uF/310Vac
FUSE (required)	1A/300V, slow-blow

Note: 1. For Smart Home and Home Appliance applications two Y-capacitors are required in series (2.2nF/250Vac each)

2. Many safety standards require a bleeder resistor no greater than 3.8MΩ in parallel with the X-capacitor.

3. R1 must be a wire-wound resistor; do not use a chip or carbon film resistor.

Circuit 3

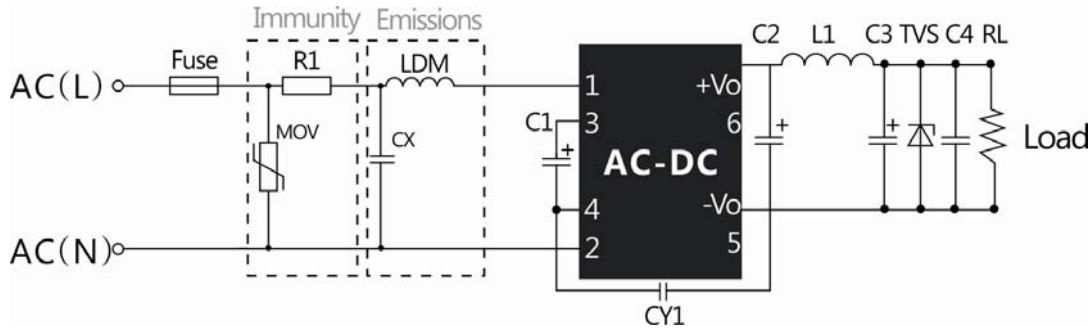

Table 3

Application enviromental	Ambient temperature range	Imunity Class	Emissions Class
Indoor industrial	-25°C~55°C	Class IV	Class B

Component	Recommended value
MOV	S14K350
CX	0.1uF/310Vac
LDM	1.2mH/4Ω/0.2A
R1(wire –wound resistor, required)	12Ω/2W
FUSE (required)	2A/300V, slow-blow

Note: 1. Many safety standards require a bleeder resistor no greater than 3.8MΩ in parallel with the X-capacitor.

2. R1 must be a wire-wound resistor; do not use a chip or carbon film resistor.

Circuit 4

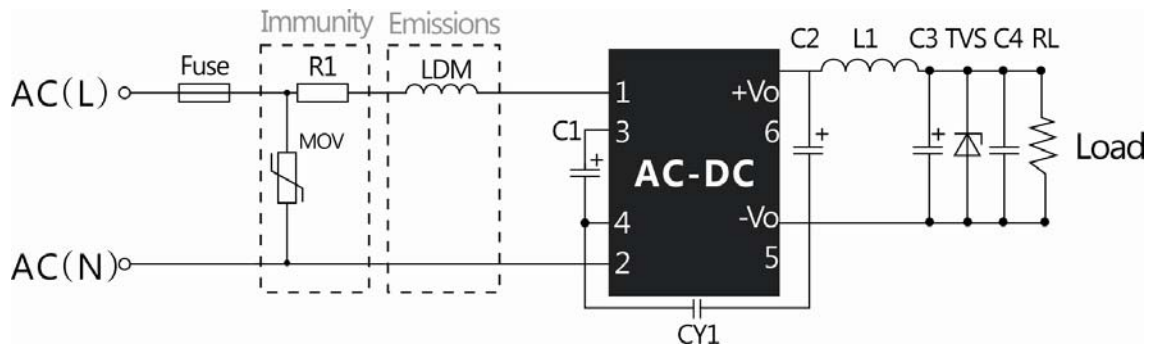

Table 4

Application enviromental	Ambient temperature range	Imunity Class	Emissions Class
Outdoor general enviroment	-40°C~85°C	Class IV	Class A

Component	Recommended value
MOV	S14K350
LDM	1.2mH/ 4Ω/0.2A
R1 (wire-wound resistor, required)	12Ω/2W
FUSE (required)	2A/300V, slow-blow

Note: R1 must be a wire-wound resistor; do not use a chip or carbon film resistor.