

## 5Watt,Single Output,AC-DC Open Frame Converter

### FEATURES:

- Universal Input 85~264VAC
- Efficiency at 82% Typical
- Protection: Short Circuit /Over Load
- Ultra small size
- 2 Years Warranty
- ROHS Compliant

$\frac{GS5}{A} - \frac{S}{B} \frac{24}{C}$

A:Series  
B:Single Output  
C:Output Voltage

Specifications typical at TA=25°C, nominal input voltage and rated output current unless otherwise specified

Part Number	Output Wattage	Output Voltage	Output Current		Efficiency	Max. Capacitive Load
	(W)	(V)	(mA)(min)	(mA)(max)	%(TYP)	( $\mu$ F)
GS5-S24C01	5	Vo=+24.0	0	210	82	100

### Input Specifications

Parameters	Conditions		Min	Typ	Max	Units
Rated input voltage	Vo,lo nom			100-240		Vac
Voltage Range	Vo,lo nom	AC in	85		264	Vac
		DC in	100		400	Vdc
Frequency			47		63	Hz
Input Current	Io nom	Vi:115VAC			0.15	A
		Vi:230VAC			0.10	A
Inrush Current	Io nom	Vi:115VAC		5		A
		Vi:230VAC		10		A

### Output Specifications

Parameters	Conditions	Min	Typ	Max	Units
Output Voltage Accuracy	Vi nom,lo nom		$\pm 1$	$\pm 2$	%
Minimum Load	Vi nom	0			%
Line Regulation	Io nom,Vi min...Vi max		$\pm 0.1$	$\pm 0.5$	%
Load Regulation	5%~100% Load		$\pm 1$	$\pm 1.5$	%
No Load				0.5	W
Ripple & Noise	Vi nom,lo nom, BW=20MHz		80	150	mVp-p
Protection	Over Load	Above 110% rated output power			
		<b>Protection type:</b> Recovers automatically after fault condition is removed			
	Short circuit	Recovers automatically after fault condition is removed			

General Specifications					
Parameters	Conditions	Min	Typ	Max	Units
Switching Frequency	Vi nom,lo nom		100		KHz
Isolation Voltage	Input / Output	3KVac/ 5mA/5Secs			
Isolation Resistance	Input / Output, @500 Vdc	100			MΩ
Operating Temperature	Operating at Vi nom,lo nom	-20		+70	°C
Storage Temperature	Non Operational	-40		+105	°C
Relative Humidity	Vi nom,lo nom			85	% RH
Safety Standards	Design refer to UL60950-1,IEC62368-1				
EMI Conduction & Radiation	EN55032,CLASS B(See Fig. 1 for recommended circuit)				
EMS Immunity	EN61000 (See Fig. 1 for recommended circuit)				
Dimension	L42.0 x W13.65 x H20.0 mm				
Cooling	Free air convection				

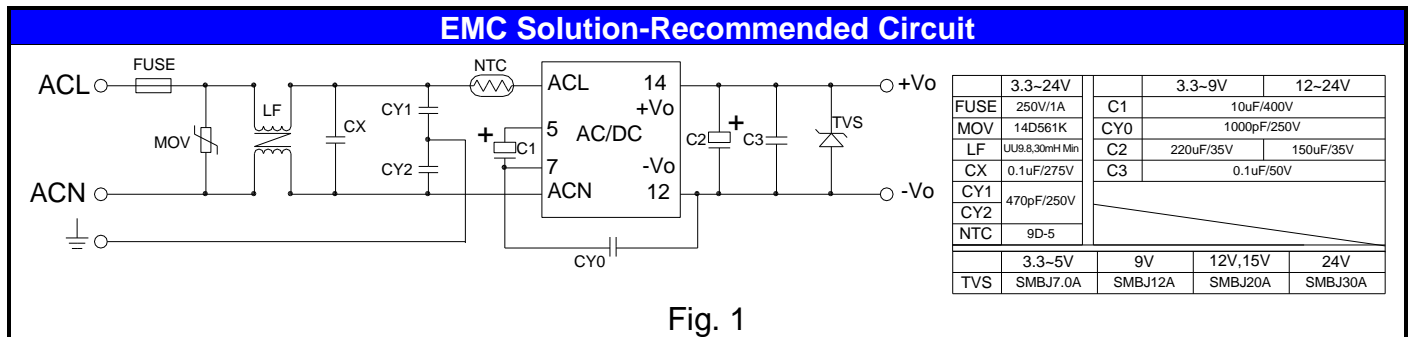
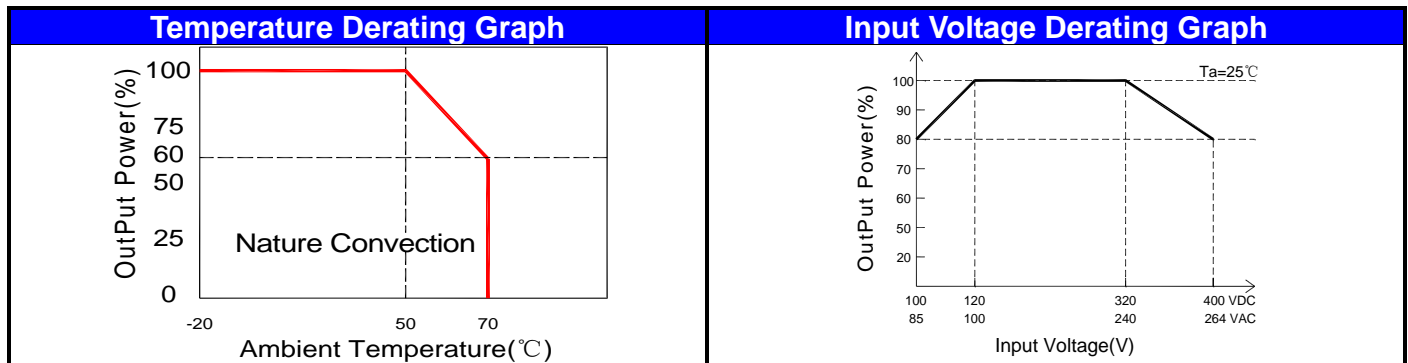

### Markings and dimensions

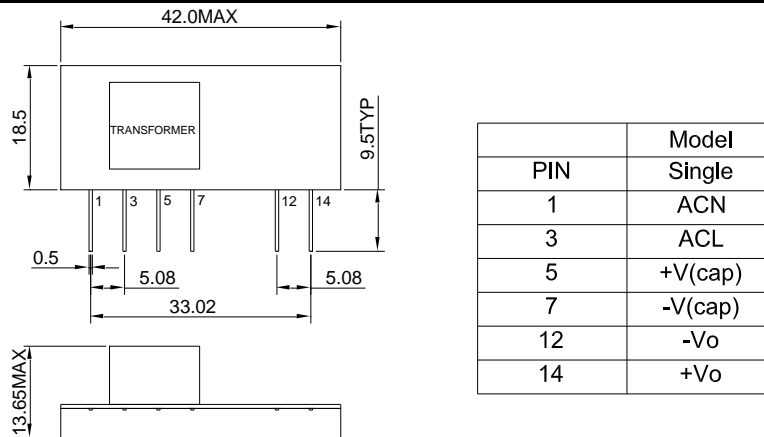

UNIT:mm Unless otherwise specified,all tolerances are ±0.5