

Features

- 3PIN SIP Package
- Pin-out compatible with LM78XX Linear
- UL94V-0 Package Material
- Operating Temperature:-40°C TO +82°C
- Efficiency up to 90%
- Non isolated, no need for heatsinks
- Short circuit protection



**NON-ISOLATED
DC/DC Converter**

Input Specifications

Input Voltage Range	:4.75~36Vdc	@When the input voltage is greater than 32V · a Pi filter must be added to the input.
Input current no load	:20mA TYP	

Output Specifications

Output Voltage	:3.3Vdc	
Output Voltage Accuracy	: ±3%	@Vout=3.201~3.399Vdc@Vin=4.75~36Vdc
Output Current	:2000mA	
Efficiency	:90% TYP	@Min Vin
	:84% TYP	@Max Vin
Ripple / Noise	:100mVp-p MAX	@20MHz Bandwidth
Short Circuit Protection	: Continuous	@automatics recovery
Line Regulation	: ±0.5% MAX	@ LL to HL at Full Load
Load Regulation	: ±0.5% MAX	@10% to 100% Load
Capacitive load	:900uF MAX	

General Specifications

Operating Temperature Range	: -40°C ~ +82°C (with derating)	Output load derate 2.86% per degree Celsius above 65°C as refer to temperature derating graph.
Storage Temperature	: -55°C ~ +125°C	
Switching Frequency	:500KHz TYP	
Humidity	:95% MAX	
Cooling	: Natural Convection	@20LFM
MTBF	:>1630000 Hours @25°C	MIL-HDBK-217F @25°C, Ground Benign.
Weight	:4.0g TYP	
Conducted Emission	: EN55022 Class A	
Radiated Emission	: EN55022 Class A	

Temperature Derating Graph **Part Number**

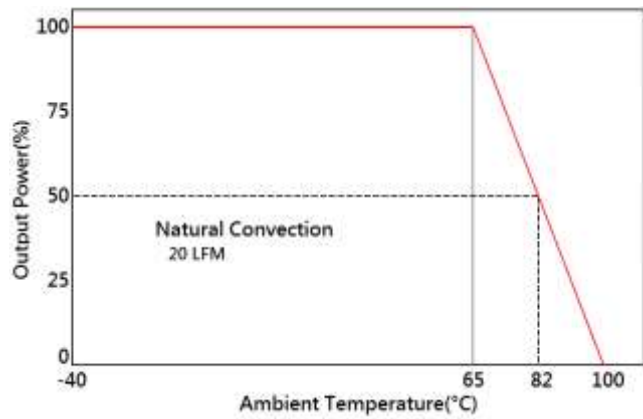

01D - **3R3** - **2A** **R**
A **B** **C** **D**

- A: Series
- B: Output Voltage
- C: Output Current
- D: Version

Outline Dimensions

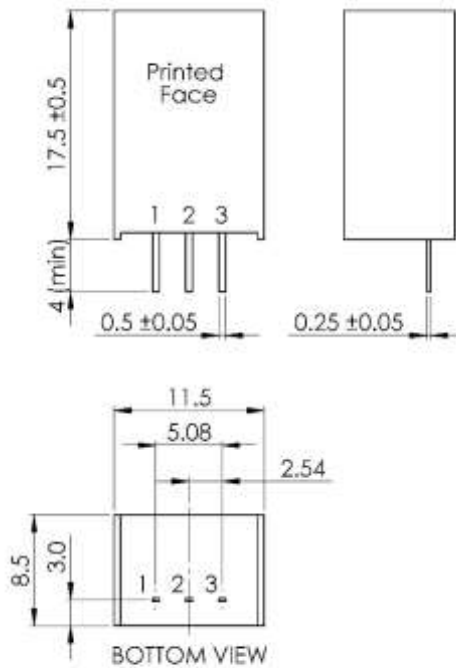

Unit : mm
 Tolerance : XX.X ± 0.5 , XX.XX ± 0.25

PIN Assignment

PIN	1	2	3
FUNCTION	+Vin	GND	+Vout

Packing Formation

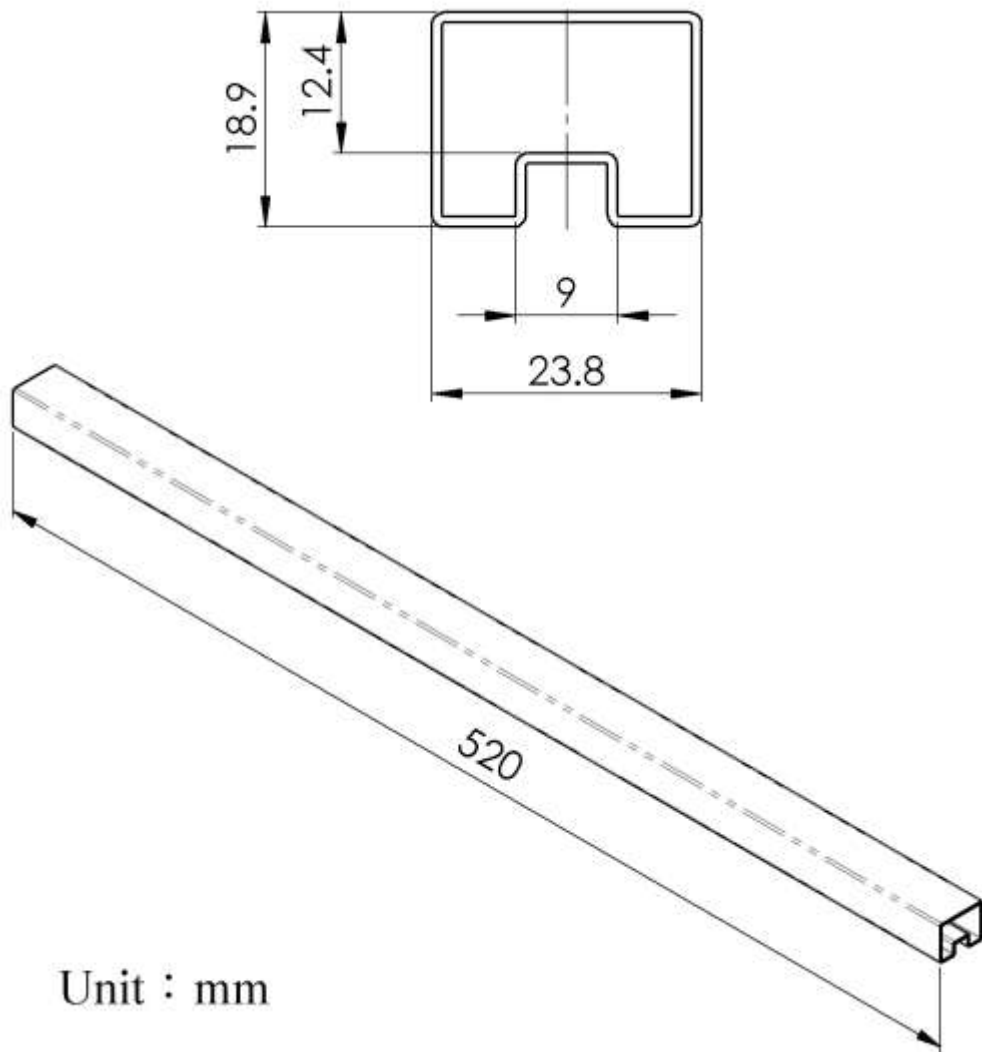

Unit : mm

Weight	: 4.0 grams/pcs
Tube	: 42 pcs