

Features

- 2WATT SIP PACKAGE
- 2:1 WIDE INPUT VOLTAGES
- EFFICIENCY TO 76%
- 100% BURNED IN
- UL 94V-0 PACKAGE MATERIAL
- CUSTOM SOLUTIONS AVAILABLE
- REGULATED OUTPUT TYPES



**2 Watt DC/DC
Converter**

WIDE INPUT VOLTAGE RANGE
2 WATT DC-DC CONVERTER

Input Specifications

Input Voltage	:24Vdc
Input Voltage Range	:18-36Vdc

Output Specifications

Output Voltage	:5Vdc	
Output Voltage Accuracy	:±5%	@Vout=4.75-5.25Vdc@Vin=18-36Vdc
Output Current	:400mA	
Efficiency	:76% TYP	
Ripple / Noise	:100mVp-p MAX	@20MHz Bandwidth
Short Circuit Protection	:Continuous	
Line Regulation	:±0.5% MAX	@ LL to HL at Full Load
Load Regulation	:±1.5% MAX	@ 0% to 100%FL

General Specifications

Operating Temperature Range	: -40°C ~ +85°C	
Storage Temperature	: -40°C ~ +100°C	
Switching Frequency	: 100KHz TYP	
Humidity	: 95% MAX	
Isolation Voltage	: 3000Vdc	@ Input to Output (60sec/0.5mA)
Isolation Resistance	: 1000MΩ MIN	@ 500Vdc
Cooling	: Free air convection	
MTBF	: >1500000 Hours	MIL-HDBK-217F@25°C, Ground Benign.
Case Material	: DAP	
Weight	: 2.7g TYP	

Temperature Derating Graph

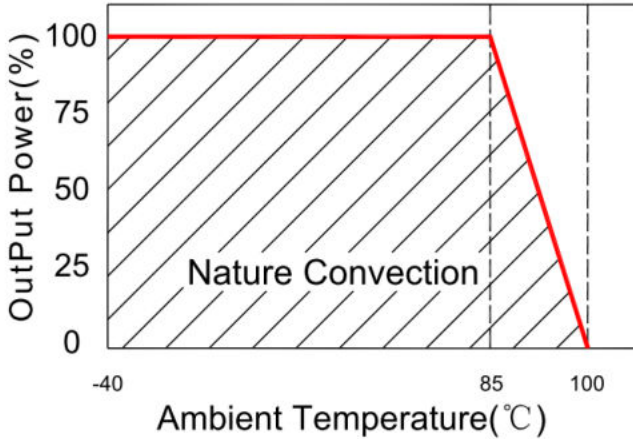

Part Number

12DZ - 24 S 05 R 2W
 A B C D E F

- A:Series
- B:Input Voltage
- C:Single Output
- D:Output Voltage
- E:Regulated(R)
- F:Output Power

Recommended Test Circuit

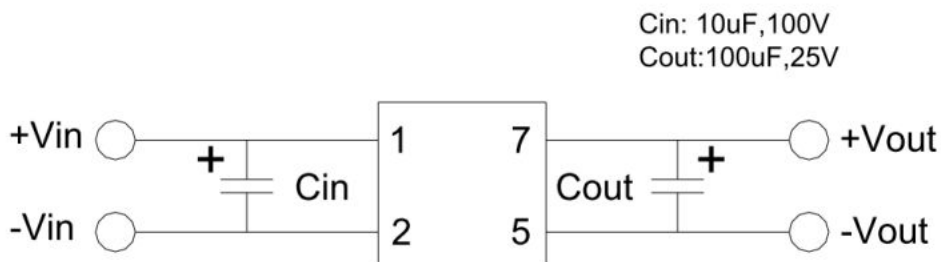

To make sure the product work at perfect operation status with full loading external capacitor is necessary and it is recommended to use high frequency low resistance electrolytic capacitor.

Outline Dimensions

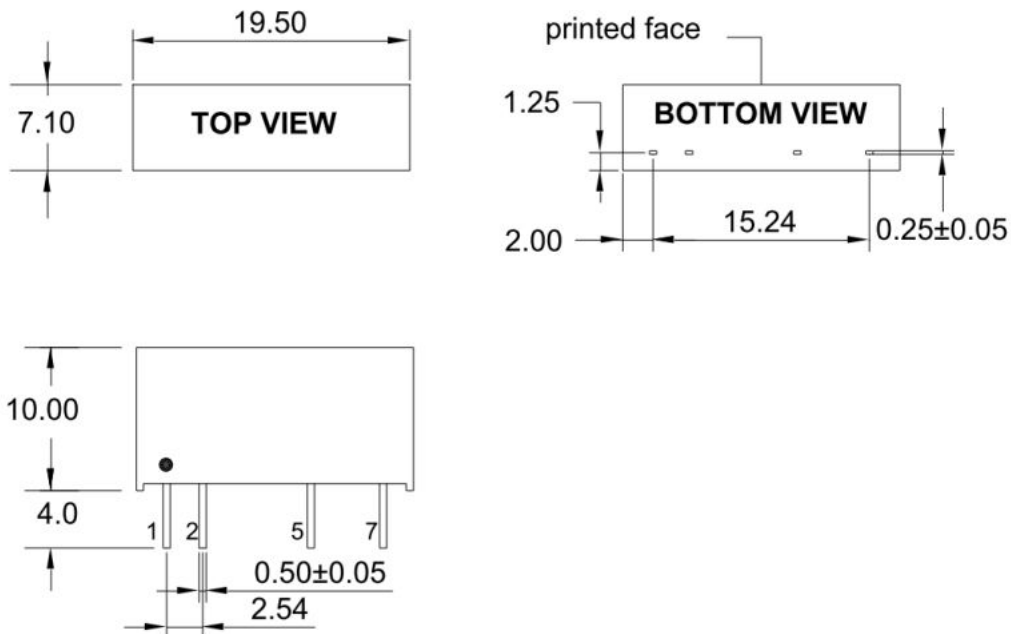

UNIT:mm Unless otherwise specified,all tolerances are ±0.25

PIN	1	2	5	7
Single	+Vin	-Vin	-Vout	+Vout

Packing Information:

Weight----- 2.7grams/pcs

TUBE-----25pcs

Weight: 80g per tube

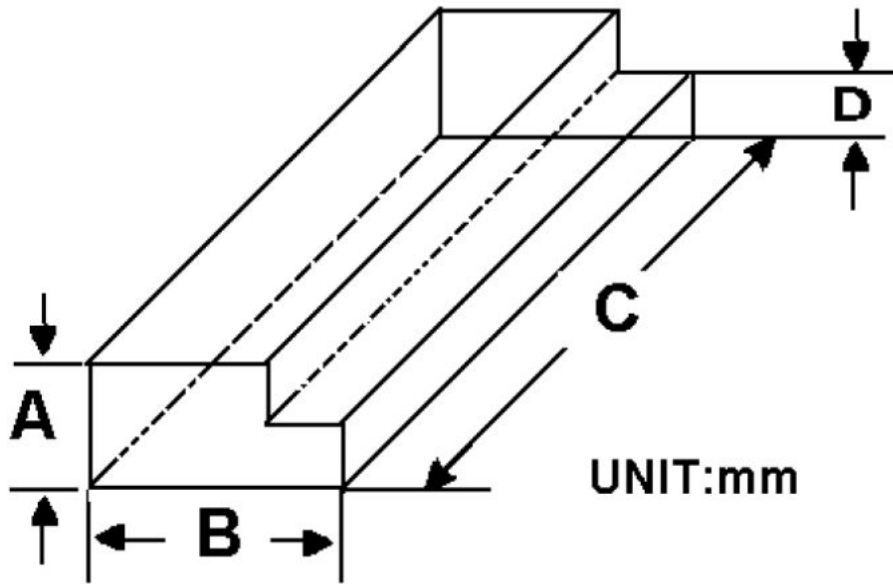

Size(mm)			
A	B	C	D
9.50	16.50	522	5.00

Outer carton unit: 2500pcs/100Tube/box

Weight: 8.5kg per carton

