

Features

- 3WATT DIL PACKAGE
- 4:1 WIDE INPUT VOLTAGES
- EFFICIENCY TO 80%
- 100% BURNED IN
- UL 94V-0 PACKAGE MATERIAL
- CUSTOM SOLUTIONS AVAILABLE
- REGULATED OUTPUT TYPES



3 Watt DC/DC Converter

WIDE INPUT VOLTAGE RANGE
3 WATT DC-DC CONVERTER

Input Specifications

Input Voltage	:5Vdc
Input Voltage Range	:4.5-18Vdc

Output Specifications

Output Voltage	:± 15Vdc	
Output Voltage Accuracy	:± 2%	@Vout=±14.7-±15.3Vdc@Vin=4.5-48Vdc
Output Current	:± 100mA	
Efficiency	:80% TYP	
Ripple / Noise	:100mVp-p MAX	@20MHz Bandwidth
Short Circuit Protection	:Continuous	@Automatics recovery
Line Regulation	:± 0.5% MAX	@LL to HL at Full Load
Load Regulation	:± 1.0% MAX	@0% to 100%FL

General Specifications

Operating Temperature Range	:-40°C ~ +85°C	
Storage Temperature	:-40°C ~ +100°C	
Switching Frequency	:330KHz TYP	
Humidity	:95% MAX	
Isolation Voltage	:3000Vdc	@ Input to Output (60sec/0.5mA)
Isolation Resistance	:1000MΩ MIN	@ 500Vdc
Cooling	:Free air convection	
MTBF	:>1500000 Hours	MIL-HDBK-217F@25°C,Ground Benign.
Case Material	:DAP	
Weight	:12.8g TYP	

Temperature Derating Graph

Part Number

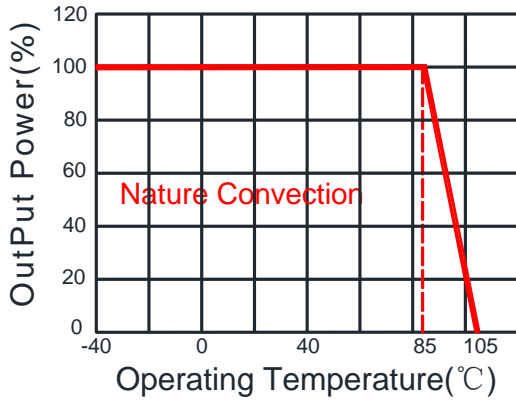

68DC - 05 D 15 R 2 3

A B C D E F G

A:Series
 B:Input Voltage
 C: Dual Output
 D:Output Voltage
 E:Regulated(R)
 F:Packge
 G:Output Power

Recommended Test Circuit

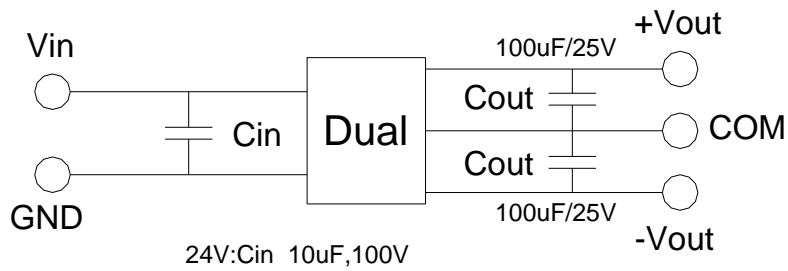

To make sure the product work at perfect operation status with full loading external capacitor is necessary and it is recommended to use high frequency low resistance electrolytic capacitor.

Outline Dimensions

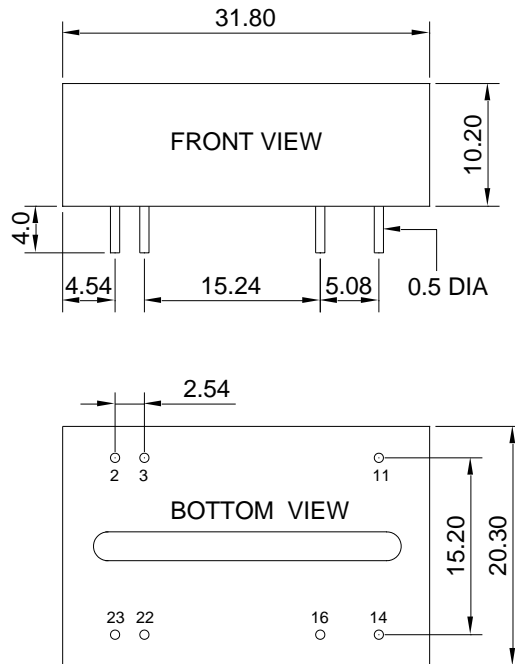

UNIT: mm Unless otherwise specified, all tolerances are ±0.25

PIN	2.3	9	11	14	16	22.23
Dual	-Vin	COM	-Vout	+Vout	COM	+Vin

Packing Information:

Weight----- 12.8grams/pcs

TUBE-----15pcs

Weight: 236g per tube

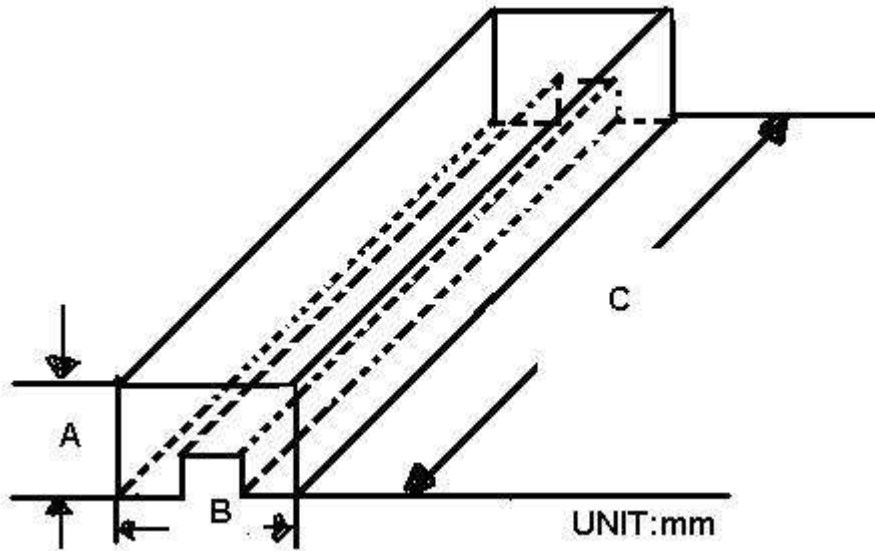

Size(mm)		
A	B	C
18.71	23.00	522

Outer carton unit: 540pcs/36Tube/box

Weight: 9.5kg per carton

