

Features

- 20 WATT DIL PACKAGE
- 4:1 WIDE INPUT VOLTAGE
- EFFICIENCY TO 88%
- PI INPUT FILTER
- 100% BURNED IN
- UL 94V-0 PACKAGE MATERIAL
- CUSTOMIZED SOLUTIONS AVAILABLE
- REGULATED OUTPUT TYPE



**20 Watt DC/DC
Converter**

WIDE INPUT VOLTAGE RANGE
20 WATT DC-DC CONVERTER

Input Specifications

Input Voltage	:48Vdc
Input Voltage Range	:18~75Vdc

Output Specifications

Output Voltage	:15Vdc	
Output Voltage Accuracy	:±2%	@14.7V~15.3Vdc @Vin=18~75V
Output Current	:1330mA	
Efficiency	:88% TYP	@Vin=48Vdc
Ripple / Noise	:100mVp-p MAX	@20MHz Bandwidth
Short Circuit Protection	:Continuous	@Hiccup, auto-recovery
Line Regulation	:±0.5% MAX	@LL TO FL ,Full Load
Load Regulation	:±0.5% MAX	@25%FL TO 100%FL

General Specifications

Operating Temperature Range	:-40°C ~ +75°C (with derating)	
Storage Temperature	:-55°C ~ +125°C	
Switching Frequency	:330KHz TYP	
Humidity	:95% MAX	
Isolation Voltage	:1500Vdc	
Isolation Resistance	:1000MΩ MIN	
Cooling	:Free air convection	
MTBF	:>=340000 Hours	MIL-HDBK-217F @25°C, Ground Benign.
Case Material	:Six-side shielded case	
Weight	:16.5g TYP	
Conducted Emission	:EN55022 Class A	
Radiated Emission	:EN55022 Class A	

Temperature Derating Graph

Part Number

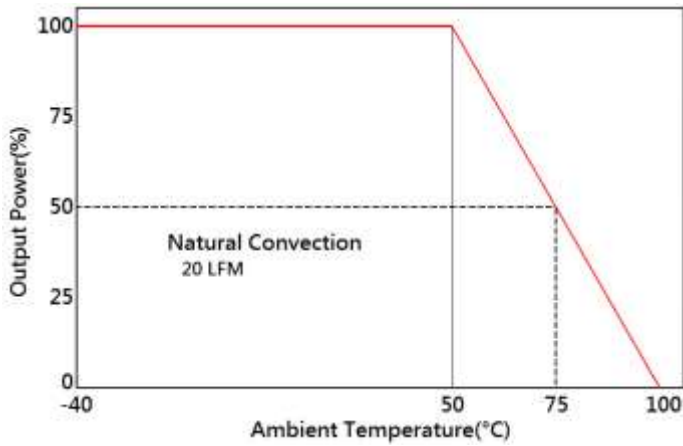

68DW20- **48** **S** **15** **R** **NL**
A **B** **C** **D** **E** **F**

- A: Series**
- B: Input Voltage**
- C: Single Output**
- D: Output Voltage**
- E: Regulated(R)**
- F: RoHs Version**

Outline Dimensions

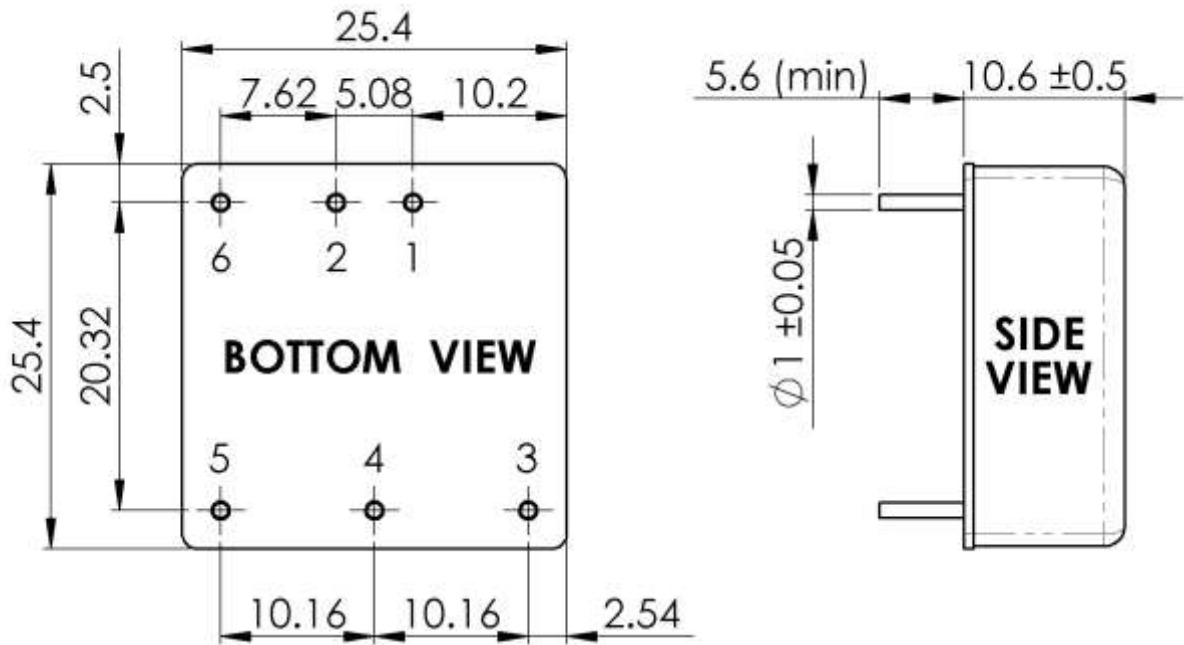

Unit : mm
 Tolerance : XX.X ± 0.5 , XX.XX ± 0.25

PIN Assignment

PIN	1	2	3	4	5	6
FUNCTION	+Vin	-Vin	+Vout	Trim	-Vout	Remote On/Off

Packing Formation

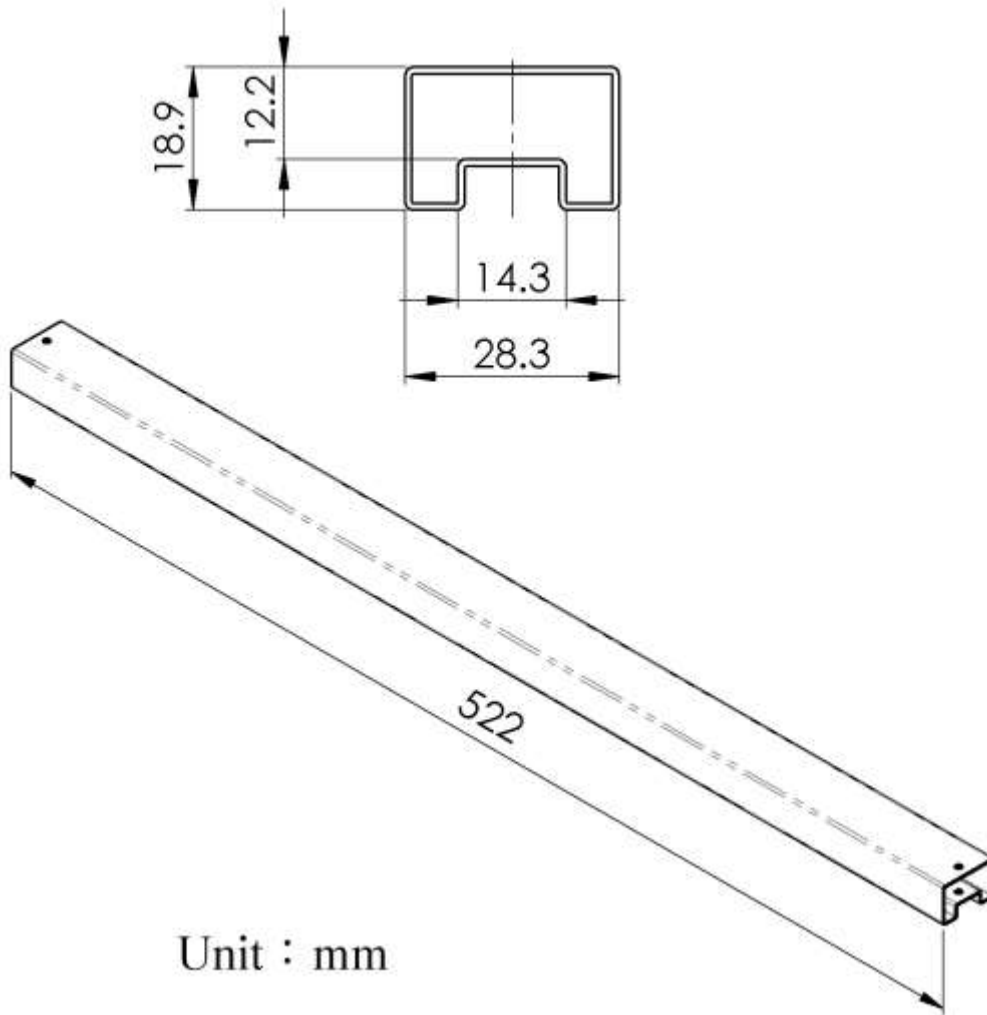

Unit : mm

Weight	: 16.5 grams/pcs
TUBE	: 19 pcs